

Thank-you for purchasing a TD 10 from an Imer U.S.A. dealer. **Your decision is an intelligent one.**

There is no other sawing machine in the world which delivers the benefits and features of the TD 10:

- Extremely rigid, mig welded bar steel frame.
- Electric motor 1.5 Hp.
- Compact design for easy transportation.
- Extremely rigid worktable for a precise cutting.

At IMER U.S.A. we continually search for ways to better serve our customers. Should you have an idea or thought to share with us regarding this product we would appreciate hearing from you. Our motto is **"Tools and Services for the 21st Century"**. We look forward to delivering the goods.

Thank you again for your purchase.

Mace T. Coleman, Jr.
President, Imer U.S.A, Inc.

IMER WEST
207 Lawrence Avenue
So. San Francisco, CA 94080
Tel 650 - 872 - 2200
Fax 650 - 873 - 6482

IMER EAST
221 Westhampton Place
Capitol Heights, MD 20743
Tel 301 - 336 - 3700
Fax 301 - 336 - 6681

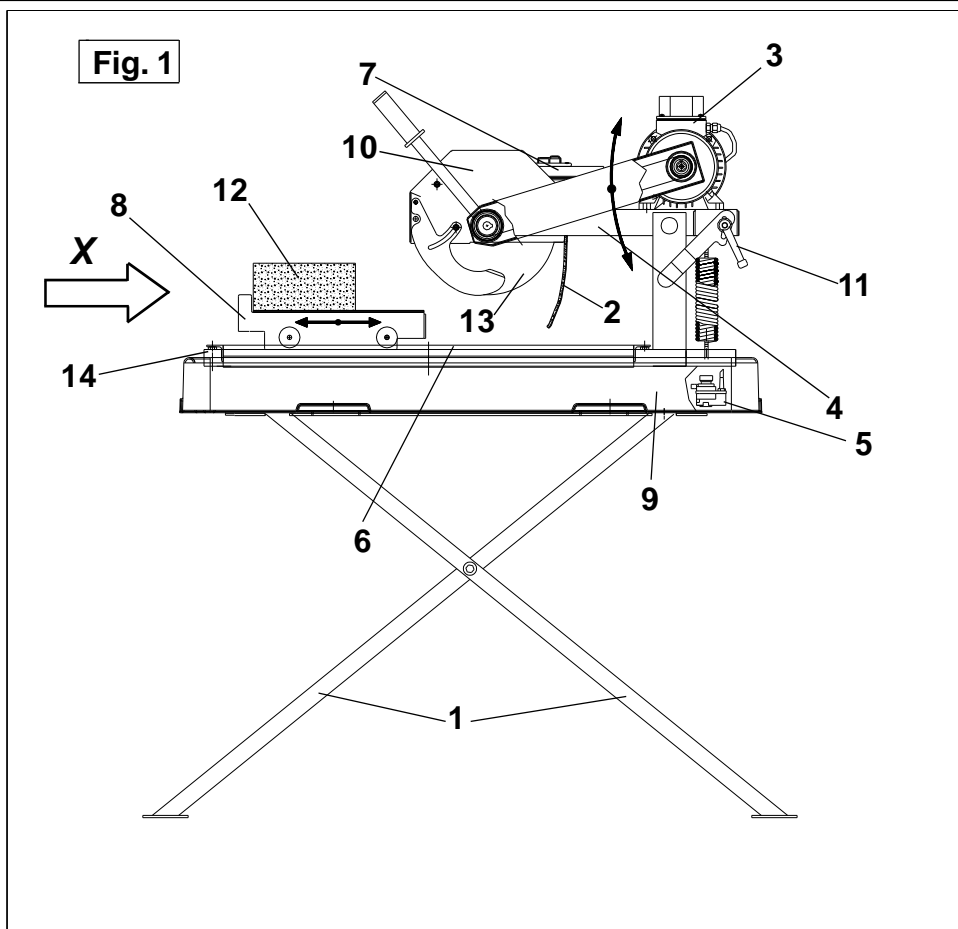

1. Trestle element
2. Spray guard
3. Motor
4. Blade support
5. Water pump
6. Guide
7. Junction box
8. Worktable
9. Water tank
10. Blade guard
11. Support locking handle
12. Work piece
13. Blade
14. Frame
15. Disc cover

Special attention must be given to warnings with this symbol:



Dear Customer,
Congratulations on your choice of purchase: this IMER saw, the result of years of experience, is a fully reliable machine and is equipped with the latest technical innovations.

! - WORKING IN SAFETY

To work in complete safety, read the following instructions carefully.

- This OPERATION AND MAINTENANCE manual must be kept on site by the person in charge, e.g. the SITE FOREMAN, and must always be available for consultation.
- The manual is to be considered part of the machine and must be kept for future reference (EN 292/2) until the machine is disposed of. If the manual is damaged or lost, a replacement may be requested from the saw manufacturer.
- The manual contains important information regarding site preparation, installation, machine use, maintenance procedures and requests for spare parts. Nevertheless, the installer and the operator must both have adequate experience and knowledge of the machine prior to use.
- To guarantee complete safety of the operator, safe operation and long life of equipment, follow the instructions in this manual carefully, and observe all safety standards currently in force for the prevention of accidents at work. Use personal protection (safety footwear, suitable clothing, gloves, goggles, etc.).

! - Safety glasses or a protective visor must be worn at all times.

! - Ear protection must be worn at all times.

! - MAKE SURE THAT WARNING SIGNS ARE ALWAYS LEGIBLE.

! - It is strictly forbidden to carry out any form of modification to the steel structure or working parts of the machine.

IMER INTERNATIONAL declines all responsibility for non-compliance with laws and standards governing the use of this equipment, in particular; improper use, defective power supply, lack of maintenance, unauthorised modifications, and partial or total failure to observe the instructions contained in this manual. IMER INTERNATIONAL is entitled to modify the characteristics of the sawing machine and/or the contents of this manual without necessarily updating previous machines and/or manuals.

1. TECHNICAL DATA

Table 1 shows the saw's technical data, referring to figure 1.

TABLE 1		
TECHNICAL DATA		1188616
Blade rpm	rpm	3400
Blade diameter	in.	10
Blade mounting hole	in.	5/8
Motor rating	Hp	1.5
Voltage	V	115
Current	A	14.4
Frequency	Hz	60
Motor rpm	rpm	3600
Cutting table dimension	in.	12" x 14"
Overall dimensions (widthxlengthxheight)	in.	23½" x 42½" x 23¼"
Overall dimensions for transport (widthxlengthxheight)	in.	24" x 43" x 23½"
Water pump flow rate	L/min	10
Water tank capacity	L	42
Weight	lb.	117
Weight for transport	lb.	134
Blade rotation direction(seen from blade clamping flange)	CLOCKWISE	

2. DESIGN STANDARDS

TD 10 saws are designed and manufactured according to the following standards: EN 292-1-2; EN 12418; EN 60204-1.

3. NOISE EMISSION LEVEL

Table 2 indicates the noise level produced by the sawing machine, measured at the operator's ear (L_{PA} at 1 m - 98/37CE) and the environmental noise emission level (power L_{WA}) measured in accordance with EN ISO 3744; UNI EN 12418.

TABLE 2			
SAWMACHINE	TYPE OF MOTOR	$L_{PA}(dB)$	$L_{WA}(dB)$
TD 10	ELECTRIC	82	92

4. CUTTING SPECIFICATIONS

This saw model has been specially designed for cutting stone, ceramics, marble, granite, concrete and similar materials. Only water-cooled diamond blades with continuous or segmented edges (see paragraph 14) must be used. Under no circumstances must dry cutting blades be used or materials other than those specified above. IMER INTERNATIONAL declines all responsibility for damage caused by improper use of the above machine.

5. CUTTING CAPACITY

- max. cutting capacity with vertical blade = 3¼" in. in one single pass.
- max. height of workpiece: 4¾" in. (in two passes).
- min. width of workpiece: 2" in.
- max. cutting length: 15" in. (with blade lowered), 19¾" in. (for max cutting height in one single pass).
- Blade at 45°: with support at 45° on the work surface.

6. WARNING

- Do not load the saw with workpieces that exceed the specified weight (max. 55 lb.).
- Ensure stability of machine: it must be installed on a solid base with a maximum slope of 5° (fig. 2).
- Ensure the workpiece is stable before, during and after cutting: in any case, workpieces must not overhang the worktable.
- Respect the environment; use suitable receptacles for collection of cooling water contaminated with cutting dust.

7. SAFETY PRECAUTIONS

IMER saws are designed for work on construction sites and under conditions of natural light, hence the workplace must be adequately lit.

! - The machine must never be used in environments subject to risks of explosion and/or underground sites

- IMER saws may only be used when fitted with all required safety devices, which must be in perfect condition.
- Never use makeshift and/or faulty power cables.
- Make electrical connections on the construction site where they will not be subject to damage. Never stand the saw on power supply cables.
- Lay power cables in such a way as to prevent water penetration. Only use connectors fitted with water-spray protection (IP67, EEC).
- Repairs to electrical installations must only be carried out by qualified technicians. Always ensure that the machine is disconnected from the power supply and is completely immobile during repairs and maintenance operations.



Fig. 3

- The symbol shown on the label (see left) indicates the warning "ENSURE ALL PROTECTION DEVICES ARE INSTALLED AND IN PERFECT CONDITION BEFORE SWITCHING ON THE MACHINE" (fig.3).

8. ELECTRICAL SAFETY

- IMER saws comply with EN 60204-1; and are fitted with:
- Protection device against automatic re-start after power failure.
 - Short-circuit cutout device
 - Motor overload cutout switch

9. TRANSPORTATION

 - **WARNING!** Before moving the saw, lock head support carriage movement by means of the relative knob (Ref. 11, fig. 1).

The saw weights 117 lb and can be moved by means of the side handles on the tank.

 Always empty the tank before moving the machine.

10. INSTALLATION

The machine must be placed on a smooth surface that is at least as large as the tank, with the saw on the relative stand (Ref. 11, fig. 1). The correct side for the operator is as shown in Fig. 1 position X.

 - Ensure that the stand is positioned on the relative inserts on the tank base and thus secured.

 - Always remove the plug from the mains power before moving the machine.

11. ELECTRICAL CONNECTION

Connect the mains power cable to the plug on the electrical panel.

 - Ensure that the electric line has a suitable differential overload switch(RCD)(GFCI-USA).

THERMAL CUTOUT PROTECTION:

 - The electric motor is protected against overload by a thermal cutout; in the event of overheating this device shuts down the motor.

Cool the motor and restart by means of the RCCB switch and the main switch on the handle .
The machine is protected against short circuits by a magnetic protection inside the RCCB.

-Ensure that the mains voltage corresponds to that specified for the machine: 115/60Hz. The electrical power cable must be suitably sized to avoid voltage drops. Cable drums must not be used.

Cables used on construction sites must be fitted with suitable external sheathing that is resistant to wear, crushing and extreme weather conditions (for example H07RN-F).

 - All power supply installations must comply with CEI 64-8 standards (harmonised document CENELEC HD384).

12. MACHINE START-UP

Before connecting the machine to the power supply:

- 1 - Ensure that the tank contains sufficient cooling water.
- 2-Connect the power supply cable to the electric panel plug.
- 3-Turn on the concrete mixer using the switch located on the electric control panel (ref. 7, fig. 1) comprising two buttons: the green one switches on the machine, while the red one switches it off. The switch has minimum voltage protection: after a power failure or accidental power loss, push the green start button to start the machine up again.
- 4 - Check that the direction of blade rotation corresponds to that indicated by the arrow on the blade guard.
Open the valve and ensure sufficient flow of cooling water to the diamond blade.
- 5 - Never dry cut material or cut when cooling water levels are low.
- 6 - If all is in order, proceed with cutting.

13. EMERGENCY STOP

 - In case of an emergency, stop the machine by pressing the red stop button (extended), then disconnect the plug from the power supply socket.

 - The motor is protected against automatic re-start after interruptions due to power failure. To resume operation, when power is re-connected, press the green switch on the overload cutout device.

14. BLADE INSTALLATION

Always remove the plug from the mains power.

 - Note that the blade must have an external diameter of 10" in., a central hole diameter of 5/8" in. and max. thickness of 1/8 in.

The diamond blade is made of material that may be damaged when subject to high temperatures, and therefore must be cooled during the work phases.

To replace the blade, proceed as follows:

1. Block axial movement of the cutting head by means of the handwheels (ref.11 fig. 1).
2. Stop the blade rotation fitting the shaft blocking pin (ref. 1 fig. 5) in the hole of the belt cover (ref. 2 fig. 5) rotating the blade till the pin has entered the hole in the shaft.
Verify that the blade doesn't turn, otherwise repeat the operation again.
3. Disassemble the front guard.
4. Loosen the locknut by rotating clockwise (left thread), using a 19 mm wrench.
5. Move the cutting head forward slightly and incline to remove the blade from its seat.
6. Ensure that there are no foreign objects between the fixing flange and diamond blade. During disassembly, avoid use of tools that could dent or deform the flange.
7. Insert the new blade proceeding in reverse order of the operation described at point 4. Take special care to ensure correct direction of rotation of the diamond blade.
8. Tighten the blade locknut fully down by rotating anticlockwise (left thread), to a torque of 40 Nm.
9. Take the shaft blocking pin off the belt cover.
10. Verify the blade turn freely.
11. Connect the plug again.

 - Check that the blade to be used is suitable for the material to be cut.

 - Do not use blades for wood! (fig. 6).

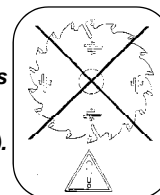



Fig. 6

15. USE

 - Leave a space of 5 ft. around the machine to operate in full safety.

- Do not allow other persons to approach the machine during cutting.
- Never use the machine in fire-risk areas. Sparks can cause fire or explosions.
- Make sure that the machine is switched off before positioning or handling.
- Always ensure that the blade is free of any contact before start-up.

 - Ensure correct installation of all protective devices.

Before starting work, fill the water tank. Top up during operation whenever necessary: N.B. the pump suction hose must always remain immersed in water.

- Insert the plug in the power socket.

 - **WARNING!** For safety purposes the removal of protective guards from the machine is strictly prohibited

 - **WARNING!** Always switch off the machine before carrying out blade adjustment.

15.1 VERTICAL BLADE MOVEMENT

To raise or lower the blade, slacken the support locking handle turning it anti-clockwise (Ref. 11, fig. 1). The blade support (Ref. 4, fig.1) remains free to rotate, so it can be secured in the desired position, fully tightening the handle (ref. 11, fig. 1).

 - Ensure that the locking handle is tightened fully before starting work.

15.2 BLADE POSITIONING FOR 45° CUTS

To make a cut at 45°, the 45° support on the carriage is necessary. Once the workpiece is correctly positioned, cutting can begin, starting the electric motor.

15.3 CUTTING

-  - **Check that the blade is aligned with the cutting line.**
- Place the workpiece on the worktable (ref. 8, fig. 1), resting firmly against the stop. Start the motor.

Wait until the water reaches the blade. Begin cutting.
- Horizontal cutting movement is carried out by pulling the carriage towards the blade.

-  - **As cutting thickness increases, the blade is subjected to greater stress. To avoid overloading the motor, the operator should continually check blade feed speed. The speed will also depend on the characteristics of the material being cut (hardness, toughness etc.).**

15.3.1 CUTS WITH BLADE LOWERED FROM ABOVE

Bring the blade support to its highest position and lock. Position the workpiece. Start the machine, unlock the blade support and begin vertical cutting until the blade reaches its lowest point. Lock the support once more and proceed with horizontal cutting

15.3.2 BLADE CHANGE

To change the blade refer to section 14.

16. MAINTENANCE

-  - **WARNING! Servicing must always be carried out by qualified technicians and only after the motor has been switched off.**

-  - **Always keep the guards in proper working order and free from damage.**

-  - **As there is the continuous risk of inadvertent damage to the electric cables, these must be checked regularly each time before the machine is used.**

Never leave the machine out in the open. Make sure that it is stored in a sheltered area away from extreme weather conditions.

Below is a list of the cleaning operations that must be carried out at the end of every shift.

Recommended product for cleaning and lubricating the mechanical parts of the saw: WD40

16.1 TANK CLEANING ON WORK COMPLETION

- Empty the tank by removing the plug. Remove cutting residue using a jet of water.

16.2 WORK SURFACE CLEANING

Always keep work surfaces clean. Residual dirt can impair cutting precision.

16.3 GUIDE RAIL CLEANING

It is good practice to remove all traces of dirt from the guides.

16.4 CLEANING AND MAINTENANCE OF COOLING CIRCUIT

- If water does not reach the blade stop the machine immediately to avoid blade damage.
- After switching off the machine ensure that the water level is sufficient.

At regular intervals (or when the flow rate of the blade cooling water is reduced) clean the cooling water supply circuit. To do this, disassemble the delivery nozzle located inside the blade guard and clean in water.

Periodically clean the cooling water delivery line between the pump and valve, and blade guard using water.

16.5 TENSIONING THE DRIVE BELT (fig. 3)

- Switch off the electric motor and remove the plug from the power supply.
- Unscrew the 4 screws that secure the movable belt guard (ref. 1).
- Loosen the 4 (ref. 2) screws that clamp the electric motor to the blade support.
- Tension the belt using the nut (ref. 3): apply a force of about F=14 lb. to the centre of the free section of the belt, the arrow should be about f=1/4" in. (fig. 4).
- Tighten the screws on the electric motor, checking the alignment of the motor pulley and the blade pulley

- Refit the guard and lock it using the 4 screws.

-  - **To avoid shortening the life of the belt, the bearings and the blade shaft, do not overtension the belt. Finally, check the two pulleys are aligned.**

16.6 DRIVE BELT REPLACEMENT

Repeat the operations described in section 16.5, replacing the belt before tensioning it

17. REPAIRS

-  - **Do not start the saw during repair work.**

Only use genuine IMER spare parts and do not modify them.

-  - **If the guards are removed to carry out repairs, they must be refitted properly when the repair work is finished.**

18. TROUBLESHOOTING

 - **WARNING!** Before carrying out any maintenance operations, switch off the machine, and remove the plug from the power socket

FAULT	CAUSE	REMEDY
Motor does not start when switch is turned	<ul style="list-style-type: none"> - Defective power cable - Plug not inserted in socket correctly - Power cable from plug to control panel detached - Loose wire inside motor circuit board - A wire has become disconnected inside the panel - Faulty main switch - The overload safety device has been activated. 	<ul style="list-style-type: none"> - Check power cables - Ensure correct connection - Connect cable- re -Connect wire - Remake the connection - Replace switch -Wait for a few minutes and then try restarting the machine.
Vertical blade movement not smooth	<ul style="list-style-type: none"> - locking knob too tight 	<ul style="list-style-type: none"> - Slacken knob
Horizontal carriage movement not smooth	<ul style="list-style-type: none"> - Guide rails dirty 	<ul style="list-style-type: none"> - Clean the guide rails
Lack of cooling water supply to blade	Refer to section : "cleaning and maintenance of cooling circuit"	
Blade does not cut	<ul style="list-style-type: none"> - Blade is worn - Drive belt not tensioned 	<ul style="list-style-type: none"> - Fit new blade -Tension the belt
Motor starts but blade does not rotate	<ul style="list-style-type: none"> - Belt is broken 	<ul style="list-style-type: none"> - Replace drive belt

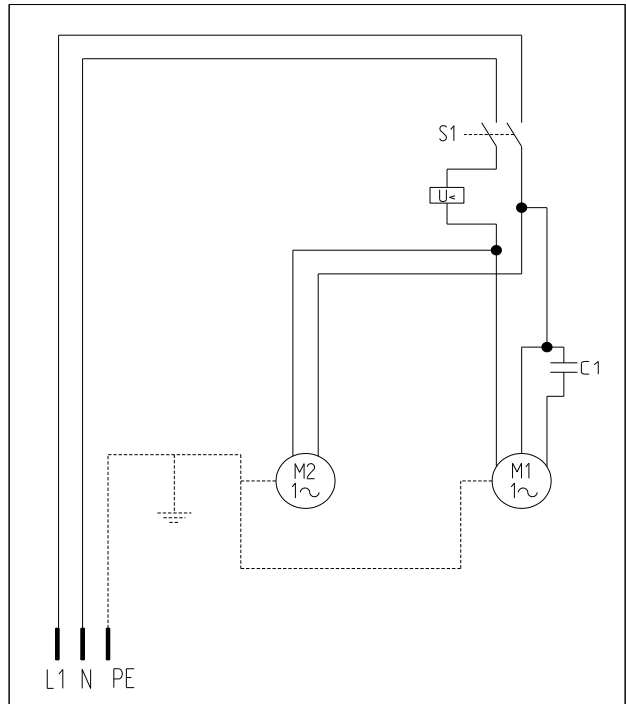

- S1 Control switch
- C1 Capacitor
- PE Earthing cable
- N Neutral line cable
- L1 Phase line conductor
- M1 Blade motor
- M2 Pump motor

19. SPARE PARTS :All orders for spare parts must indicate the following: 1 - Type of machine.2 - Part number and position number of each part.3 - Serial number and year of manufacture reported on the machine's identification plate.

SYMBOL: Interchangeability (example):Pos..1 P.n. 2222002 was installed on machincs up to N° 5240 and Pos.1.1 P.n. 2222018 installed on machine N° 5241 onwards. Pos. 1.1 is interchangeable () with Pos. 1.Pos. 1 and Pos. 1.1 are not interchangeable if the () symbol appears in the table.

SPARE PARTS			NOTES
Ref.	Code		
1	2222002	SCREW	5240
2	2222018	SCREW	5241

TAV1 - STRUCTURE MACHINE -			
RIF.	COD.		NOTE
1	3210768	FRAME	
2	3210789	COUNTER-FRAME	
3	3223602	LABEL	
4	2224140	WASHER	6593 8X18 Z
5	3208414	LEVER	
6	3207129	NUT	5589 M8 Z
7	2223923	SELF LOCKING NUT	7473 M8 Z
8	3210152	SPRING	
9	3210760	CARRIGE	
10	3210767	RUBBER COATING	
11	3210765	SLIDE-TROLLEY SHEET	
12	1222050	SCREW	5739 M8X50 Z
13	3210766	SPACER BRACKET	
14	3207525	WHELL	
15	2223570	NUT	5588 M8 Z
16	2222190	SCREW	5739 M8X40 Z
17	3210841	JUNCTION BOX	115V/60HZ
18	3210804	BELTS EXETRNAL COVER	
19	2222420	SCREW	6950 4.8X13 Z
20	3208791	BELT	340J6
21	3210805	BELTS INTERNAL COVER	
22	2222021	SCREW	5739 M6X16 Z
23	3210840	MOTOR	Hp.1.1 115V/60HZ
24	2222006	SCREW	5739 M8X30 Z
25	3210806	PULLEY	D.40 J6
26	2225146	GRUB-SCREW	5923 M6X10 Z
27	2223924	SELF LOCKING NUT	M6 Z
28	2224531	WASHER	6593 6X18 Z
29	3210779	CUTTING HEAD GROUP	
30	2288885	HANDGRIP	
31	2209400	NYLON BUSHING	
32	2223921	SELF LOCKING NUT	M12 Z
33	2228395	PIN	1481 5X20
34	3210803	ROD	
35	2227320	STOP RING	7435 E/20
36	3208919	PULLEY	
37	3209055	SPACER BRACKET	
38	3208622	BEARING	6204 2RS FAG-SKF
39	2229250	LEVER	5X5X15
40	3210808	SHAFT	
41	3210815	BEARING	6004 2RS FAG-SKF
42	3210864	OUTER	
43	1193853	DISK	
44	3210812	OUTER	
45	3210053	NUT	5588 M12 Z SX
46	3210802	BLADE COVER	
47	3210796	DISC COVER	
48	2222021	SCREW	5739 M6X16 Z
49	3210793	DISK PROTECTION DX	
50	3210794	DISK PROTECTION SX	
51	3210576	NYLON WASHER	8.4X17X1.5
52	3210206	WASHER	
53	3210842	SCREW	5739 M6X70 Z
54	3210055	TANK	
55	3210524	WATER PUMP	S0 115V/60HZ
56	2235429	CAP	
57	3207884	COCK	
58	2226850	Y SHAPED JOINT	
59	2292365	TUBE	
60	3210763	RIGHT FENCE ADHESIVE LABEL	
61	3210764	LEFT FENCE ADHESIVE LABEL	

TAV.1

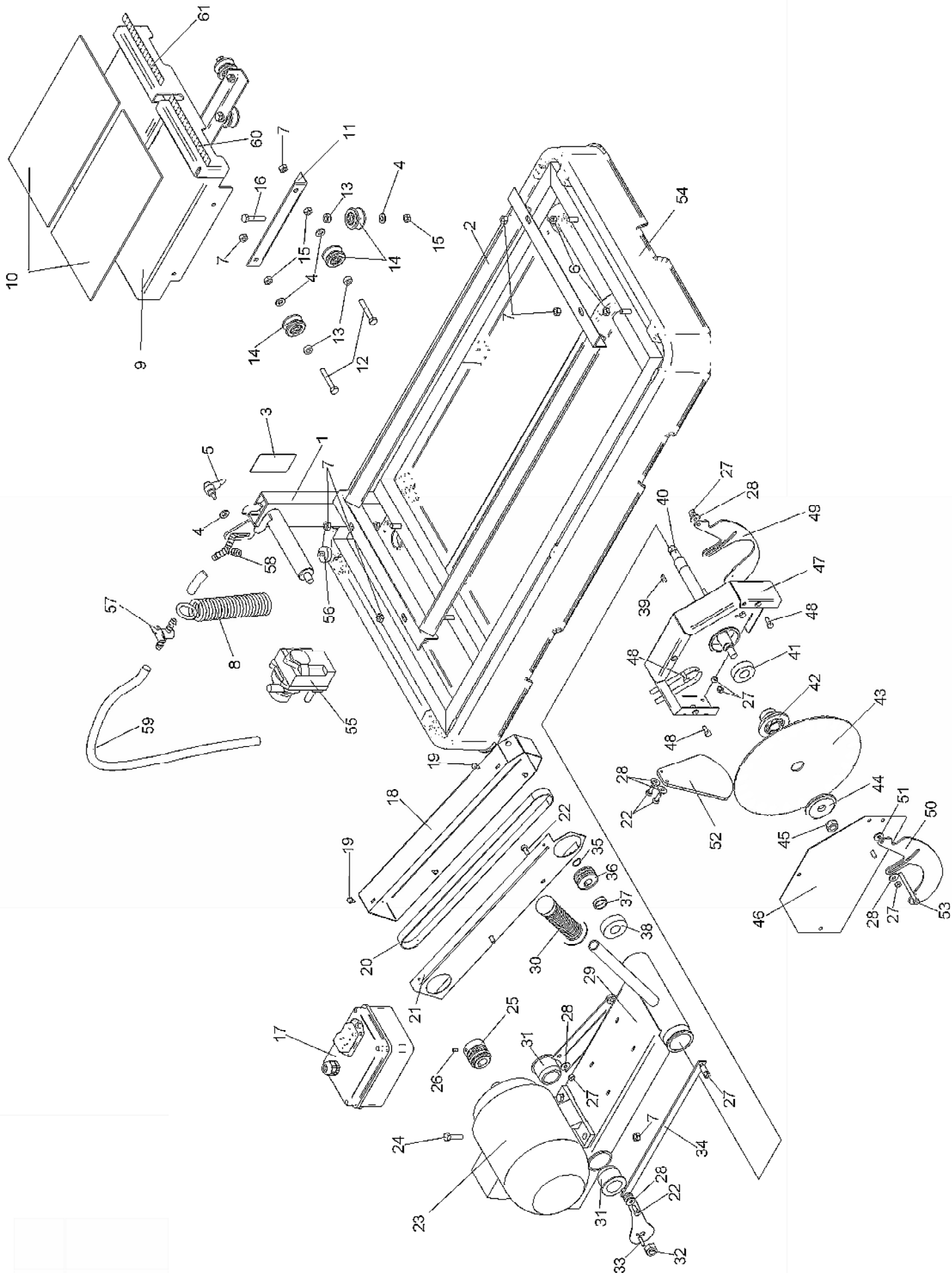

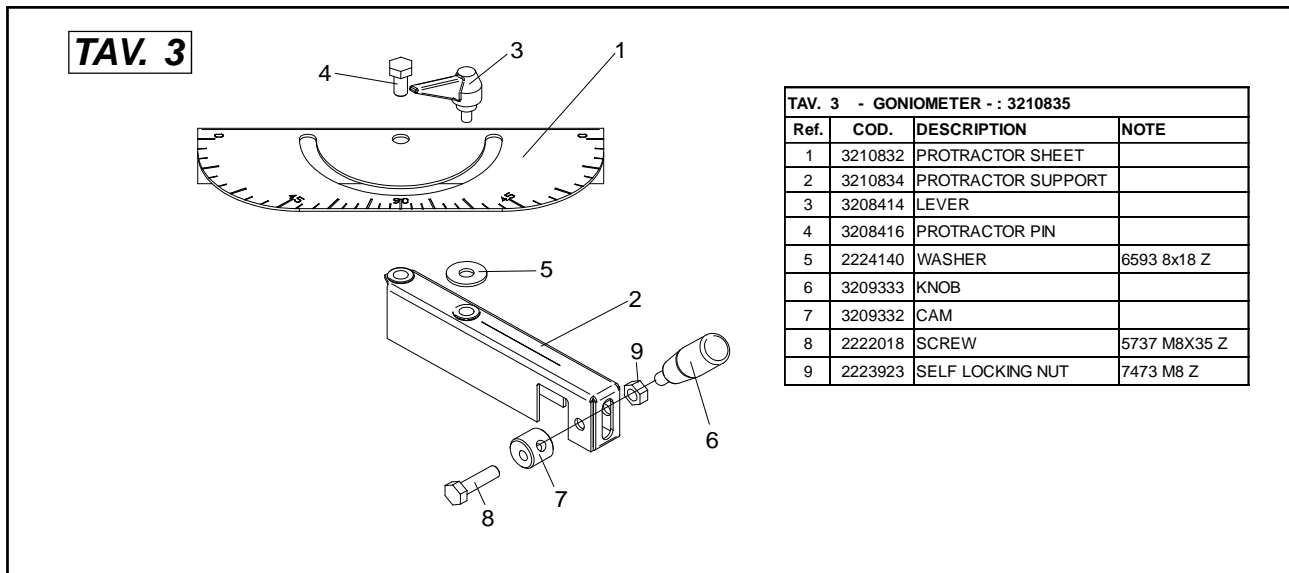
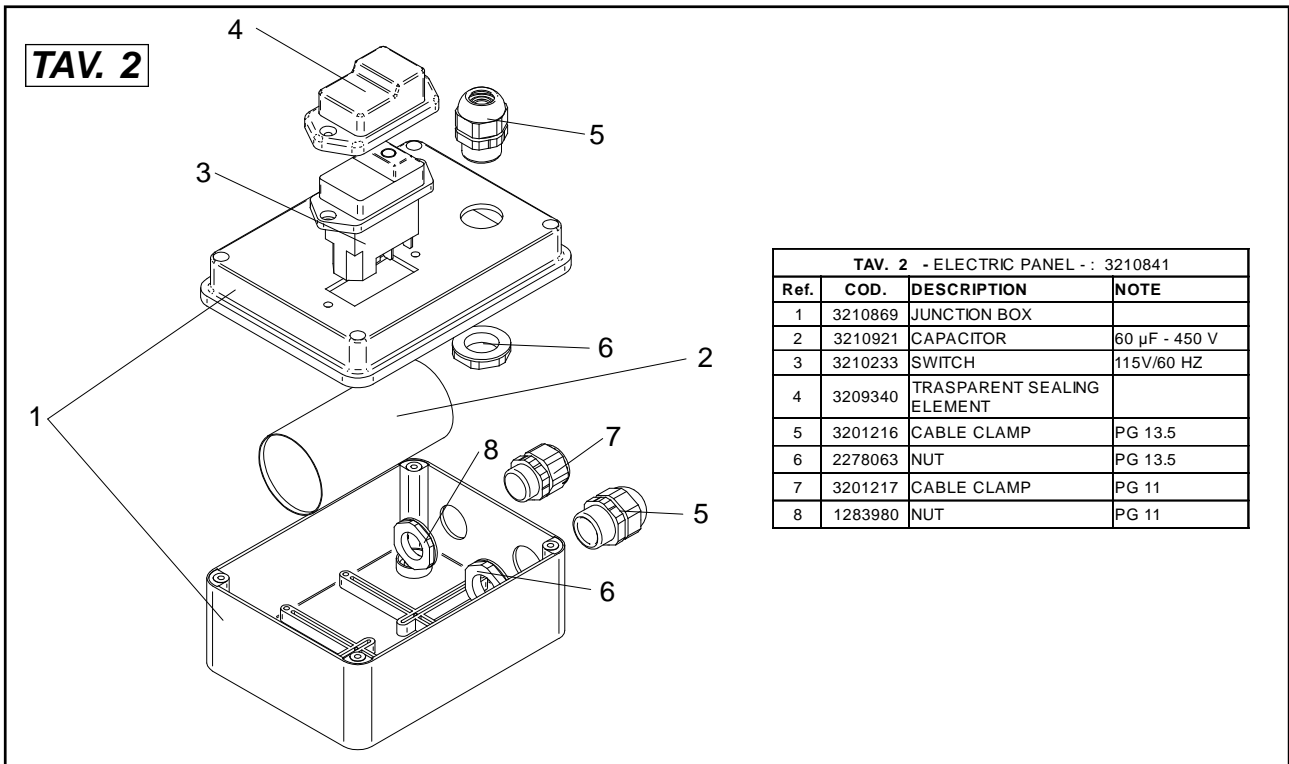

TAV. 4

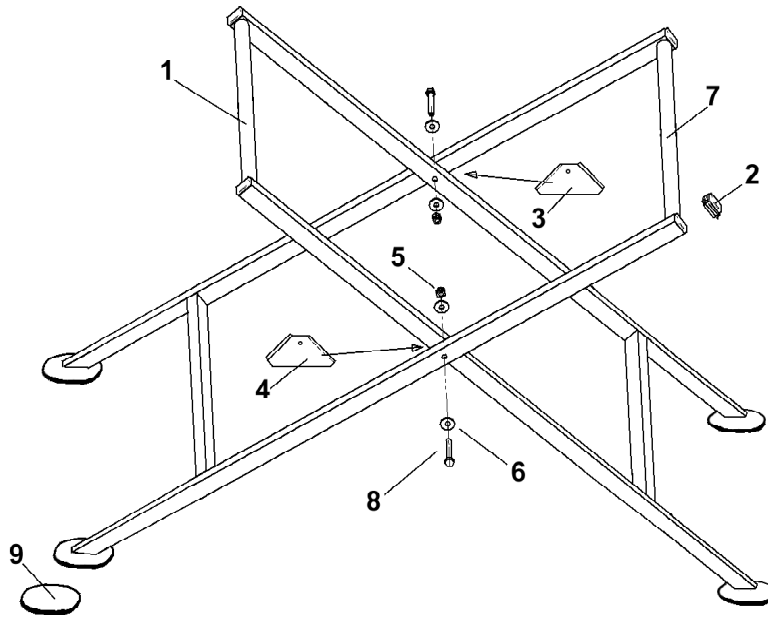

COD.3210080		TAV 6 - TRESTLE ELEMENT	
Ref.	Code	Description	Notes
1	3210645	INTERNAL TRESTLE ELEMENT	
2	3206205	TERMINAL	
3	3207193	RIGHT RABBET	
4	3207194	LEFT RABBET	
5	2223924	NUT	AUTOBL. M8
6	2224204	WASHER	6593 8x24
7	3210641	EXTERNAL TRESTLE ELEMENT	
8	1222030	SCREW	5737 8x60
9	3210646	RUBBER COATING	

TAV. 5

OPTIONAL

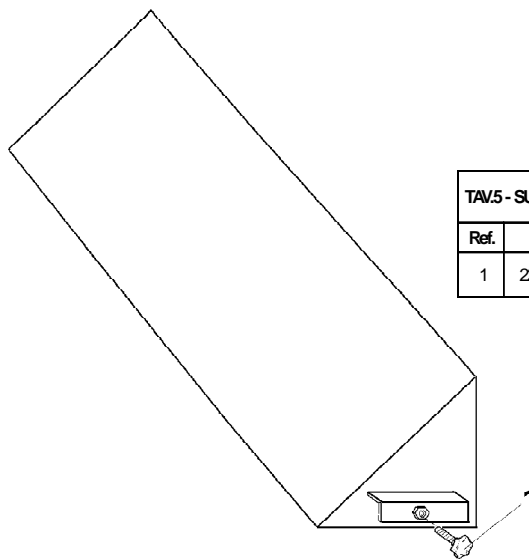

TAV/5 - SUPPORT 45° - COD.1187623			
Ref.	Cod.	GB	Note
1	2284859	KNCB	

ONE YEAR WARRANTY

We warrant to the original purchaser that the IMER equipment described herein (the "equipment") shall be free from defects in material and workmanship under normal use and service for which it was intended for a period of one (1) year from the date of purchase by the original purchaser.

Our obligation under this warranty is expressly limited to replacing or repairing, free of charge, F.O.B. our designated service facility, such part or parts of the equipment as our inspection shall disclose to be defective. Parts such as engines, motors, pumps, valves, electric motors, etc. furnished by us but not manufactured by us will carry only the warranty of the manufacturer. Transportation charges or duties shall be borne by the purchaser. This shall be the limit of our liability with respect to the quality of the equipment.

This warranty shall not apply to any equipment, or parts thereof, which has been damaged by reason of accident, negligence, unreasonable use, faulty repairs, or which has not been maintained and operated in accordance with our printed instructions for our equipment. Further, this warranty is void if the equipment, or any of its components, is altered or modified in any way.

THIS WARRANTY IS EXPRESSLY IN LIEU OF ALL OTHER WARRANTIES, EXPRESSED OR IMPLIED, INCLUDING ANY IMPLIED WARRANTY OF MERCHANTABILITY OF FITNESS FOR A PARTICULAR PURPOSE.

We make no other warranty, representation or guarantee, nor is anyone authorized to make one on our behalf. We shall not be liable for any consequential damage of any kind, including loss or damage resulting, directly or indirectly, from the use or loss of use of the machine. Without limiting the generality of the foregoing, this exclusion from liability embraces the purchase's expenses for downtime, damages for which the purchaser may be liable to other persons, damages to property, and injury or death of any persons.

This warranty shall not be deemed to cover maintenance parts, including but not limited to blades, belts, hoses, hydraulic oil or filters, for which we shall have no responsibility or liability whatsoever.

IMER U.S.A., Inc.
207 Lawrence Avenue
South San Francisco, California 94080
(650) 872-2200

T D 10
110 VOLT

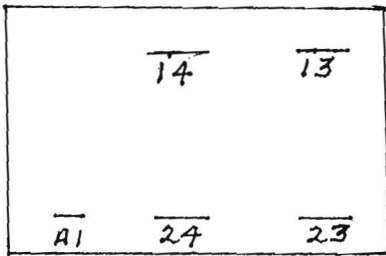
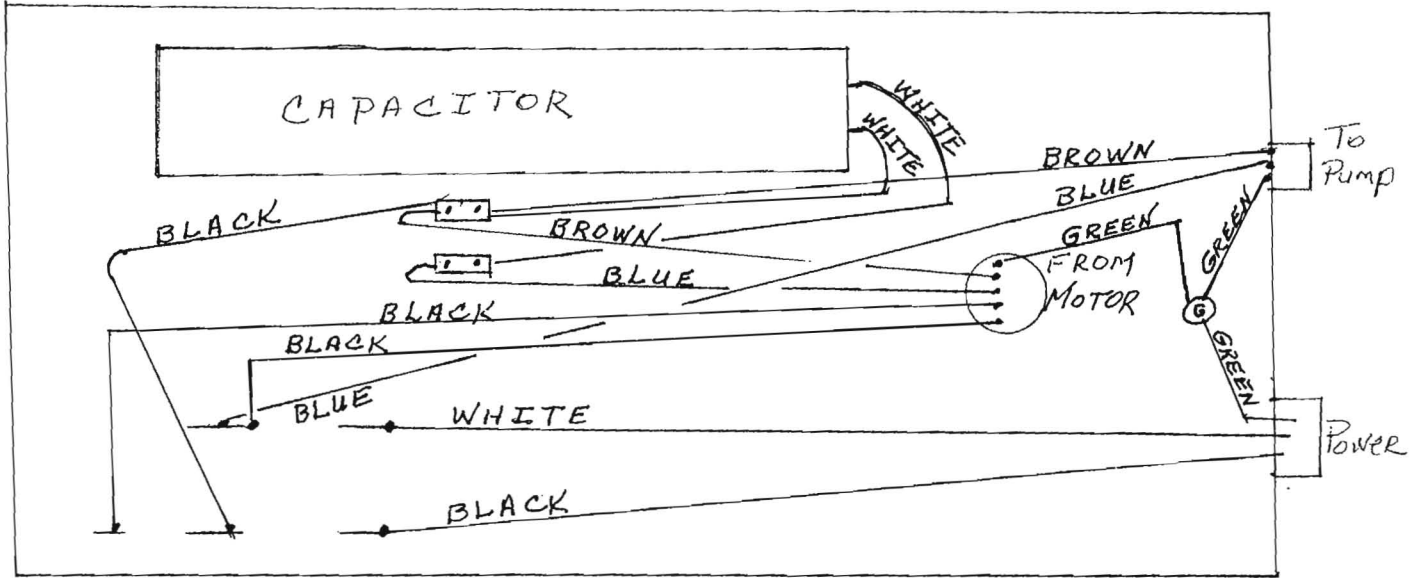

SWITCH

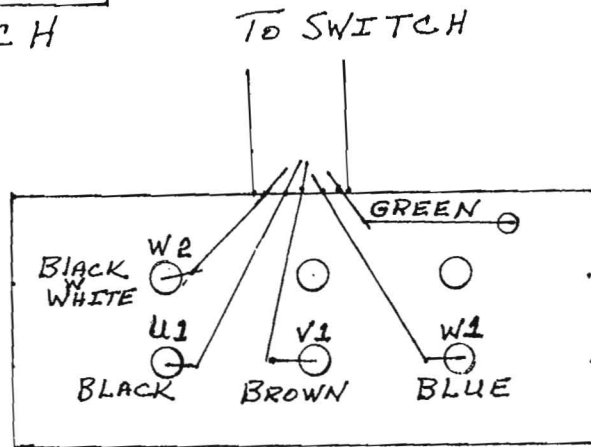

MOTOR

2/13/09
DAN



This is a contact addendum to our manuals

Imer USA East

221 Westhampton Pl
Capitol Heights, MD 20743

Phone: 301-336-3700

Fax: 301-336-6687

Order Fax:301-336-5811

Imer USA West

3654 Enterprise Ave
Hayward, CA 94545

www.imerusa.com

800-275-5463